

● ベランダ手すり壁面用取付金具

1. NBS-200J (RoHS対応)
2. NBS-300J (RoHS対応)
3. NBS-400J (RoHS対応)
4. NBS-600J (RoHS対応)

● BS・CSアンテナ屋根用架台

5. NBS-100Z
6. NBS-120Z

● BS・CSアンテナ取付金具

7. NBSK
8. NBSK-L
9. NBKS
10. NBKL

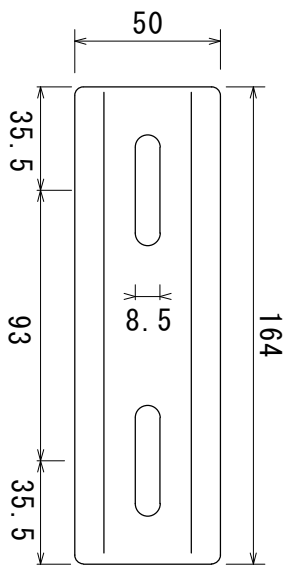
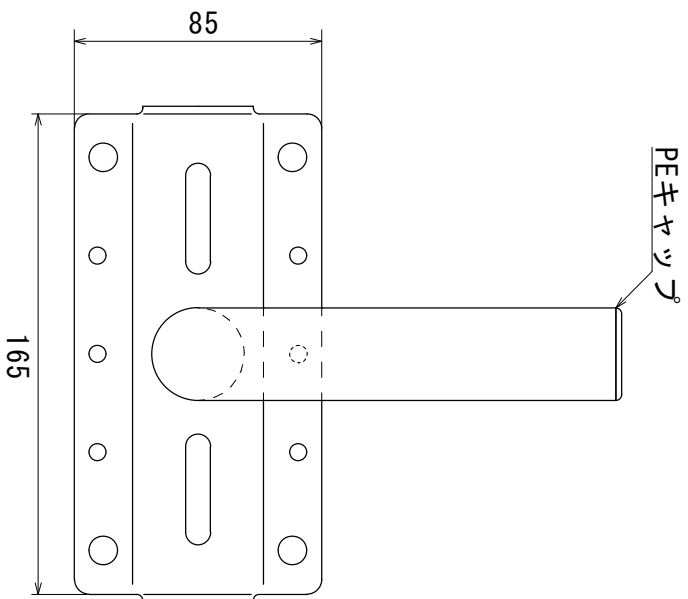

当て板

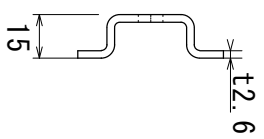

表面処理	種類
溶融亜鉛めっき	品名
	NBS-200J

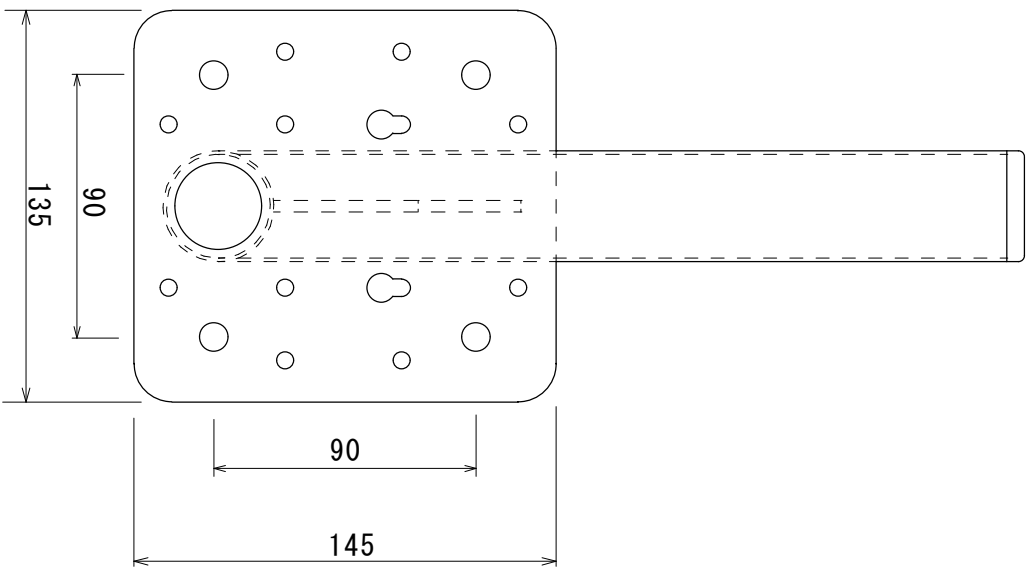
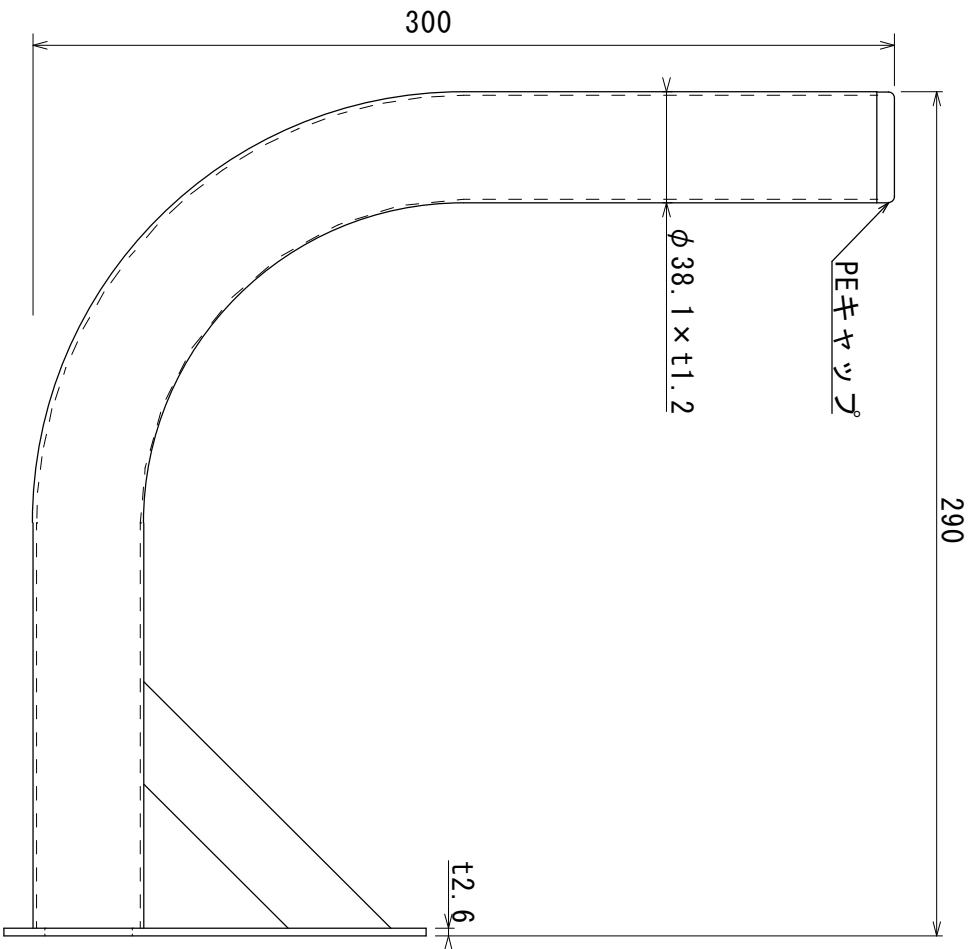

表面処理	種類別
溶融亜鉛めっき	品名
	NBS-300J

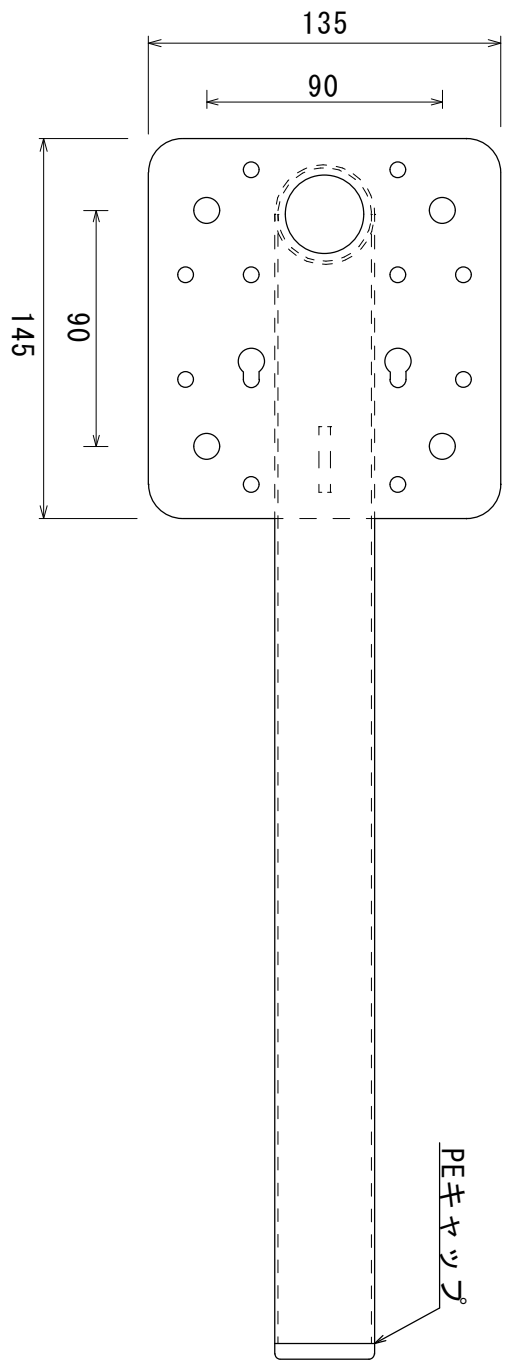
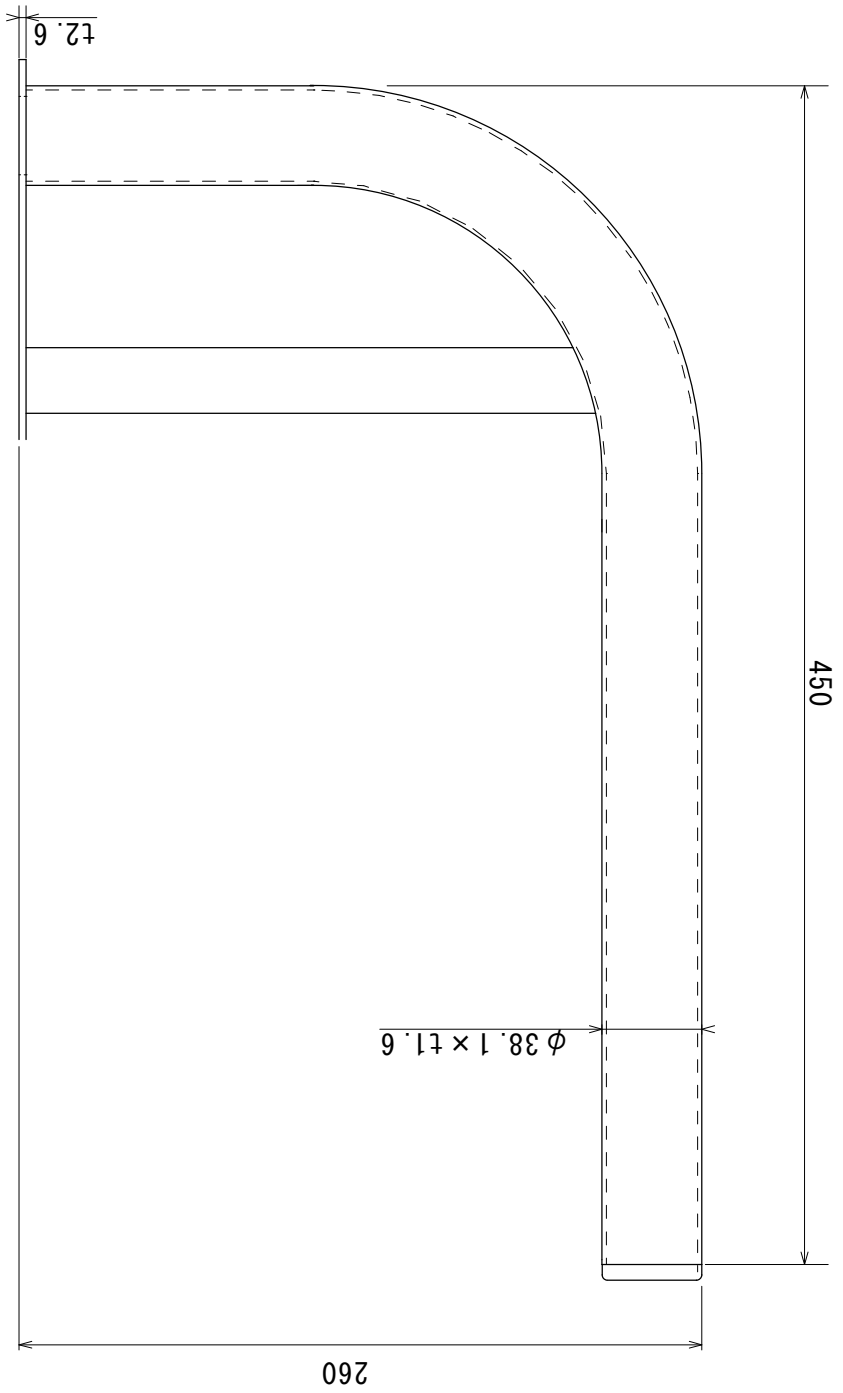

表面処理	種類別
溶融亜鉛めっき	
品名	
NBS-400J	

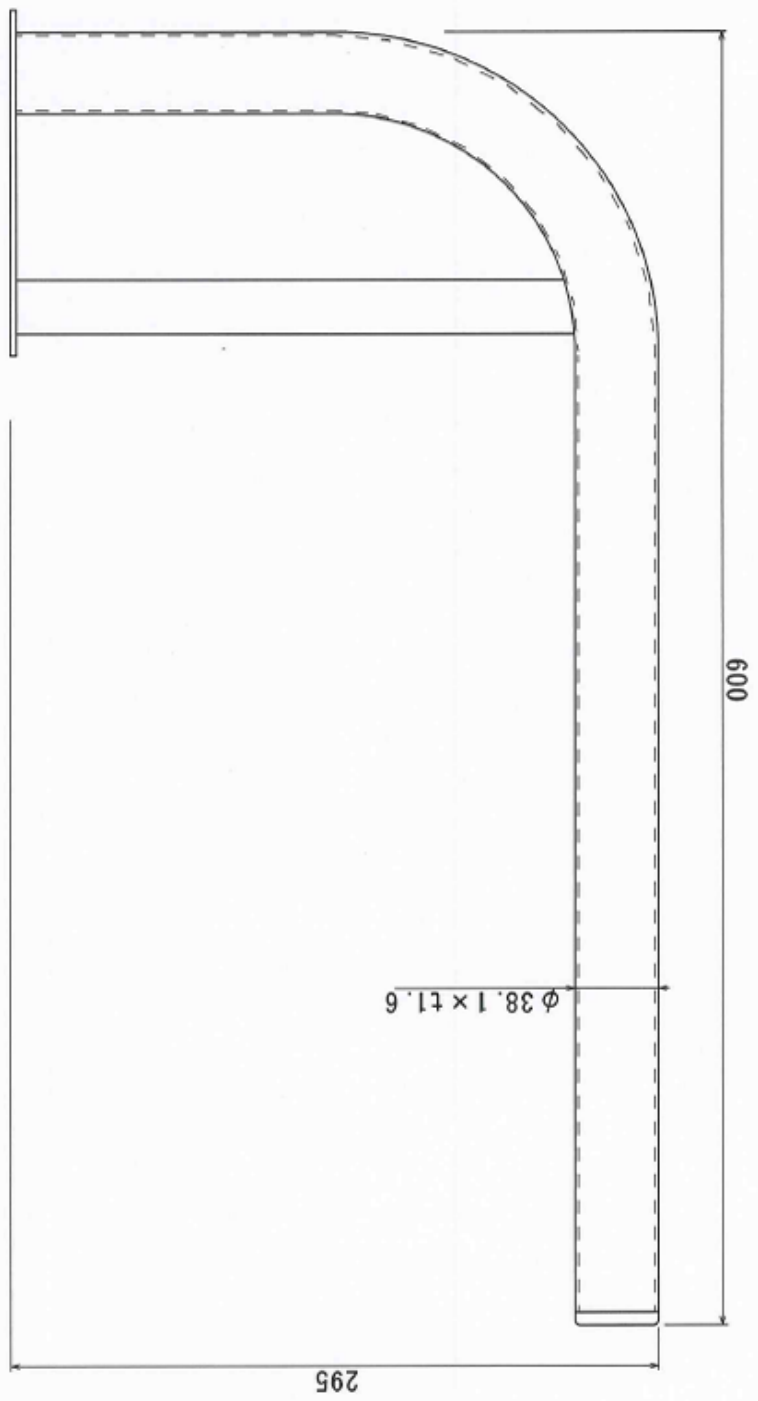
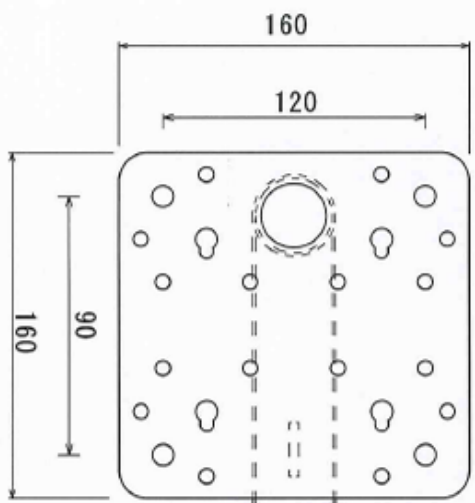

PEキヤツプ

表面処理	
種類	
品名	NBS-600J
溶融亜鉛めっき	

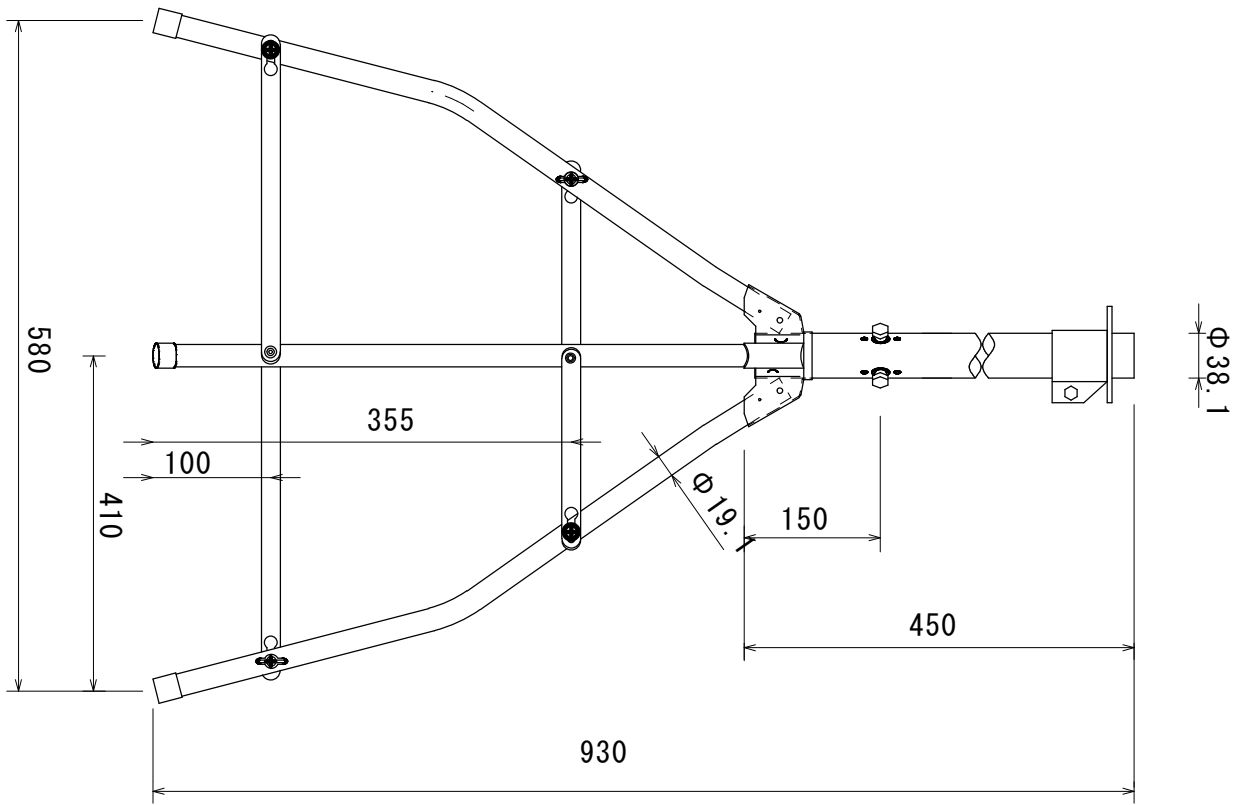

表面処理	種類
溶融亜鉛めっき	NBS-100Z
品名	

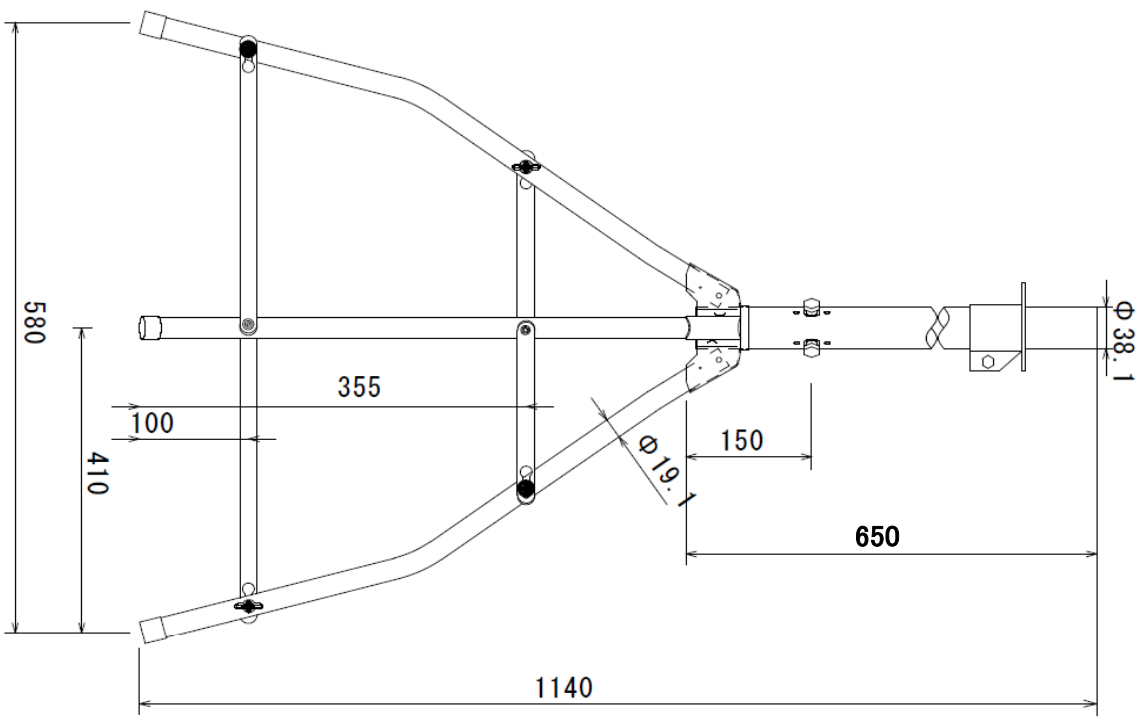

表面処理	
種類	
品名	NBS-120Z
溶融亜鉛めっき	

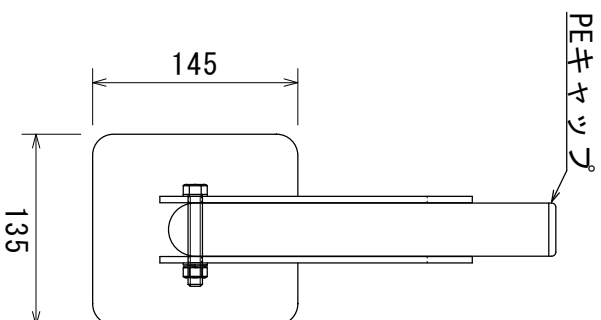
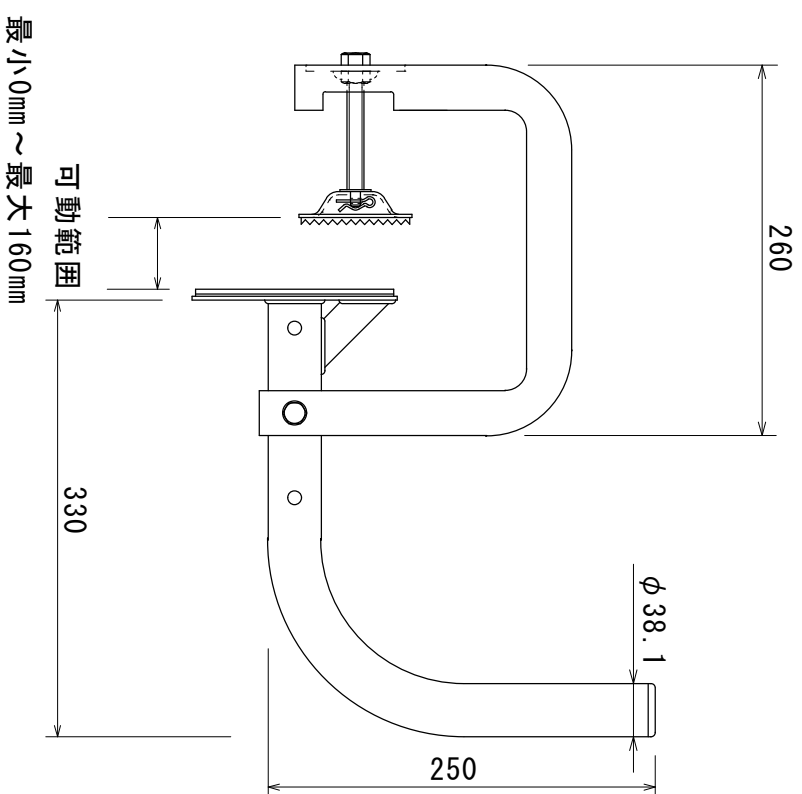
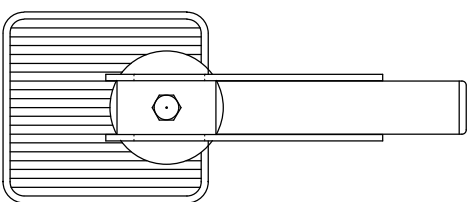

表面処理	種別
溶融亜鉛めっき	
品名	NBSK

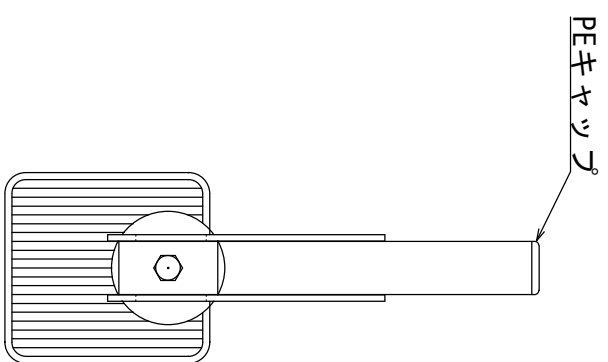
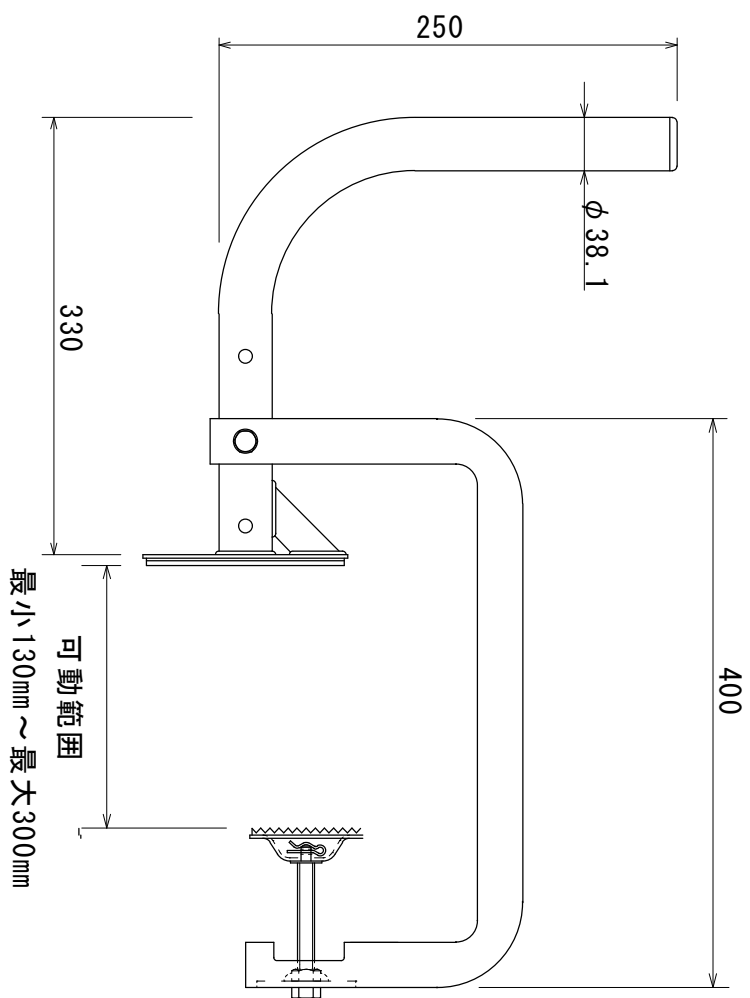
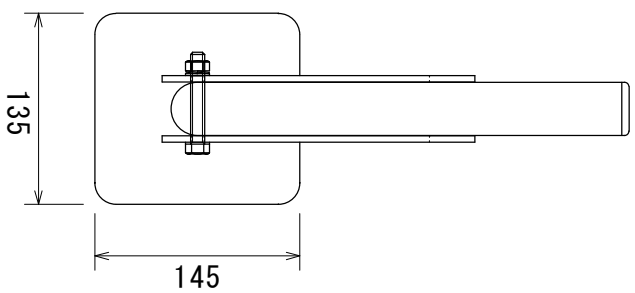

表面処理	種類
溶融亜鉛めっき	NBSK-L

φ38.1×t2.0 L=450

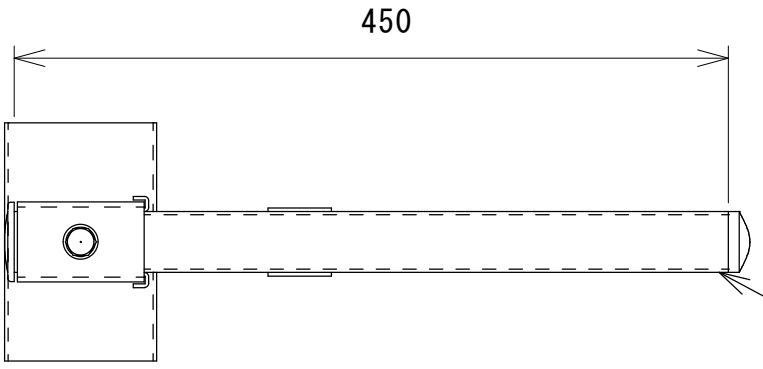

PEキヤップ

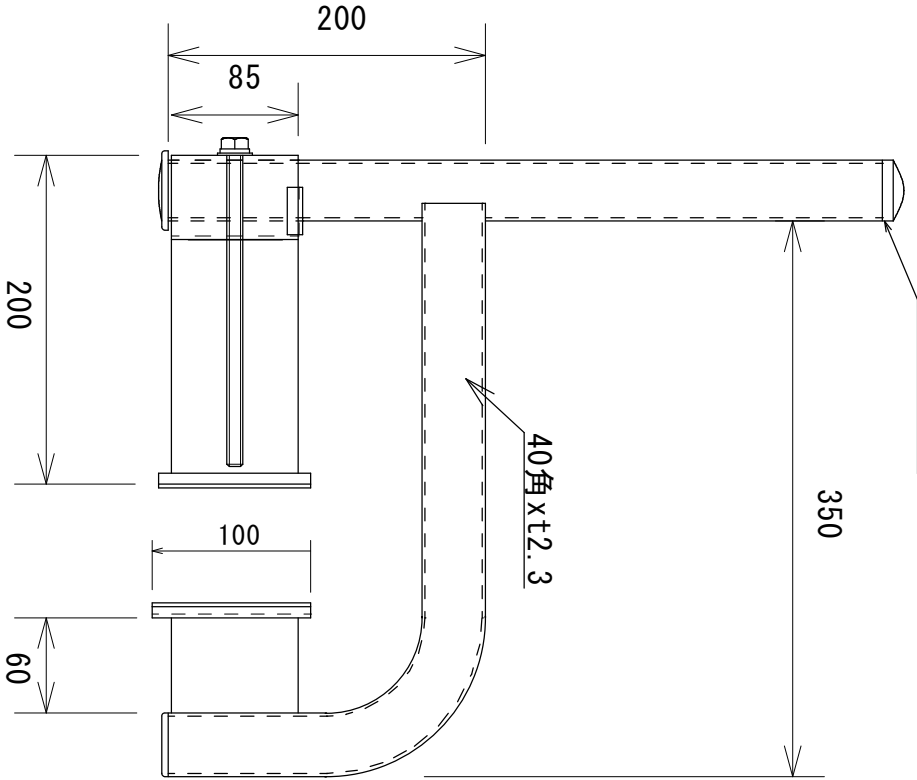

40角×t2.3

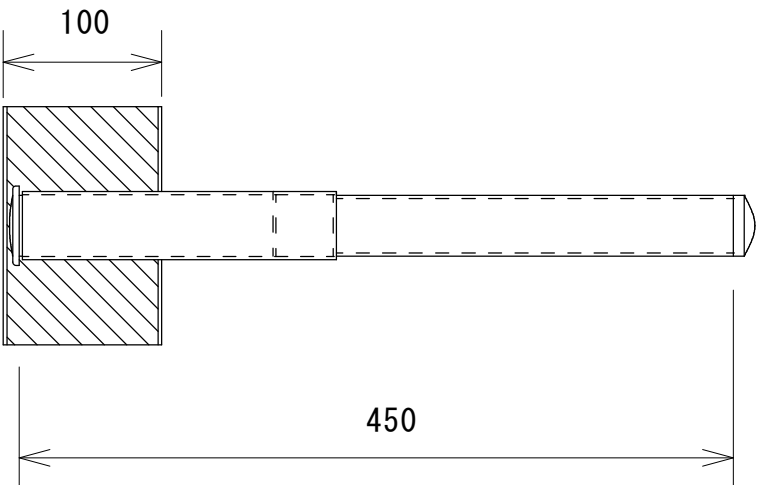

可動範囲

最小80mm～最大200mm

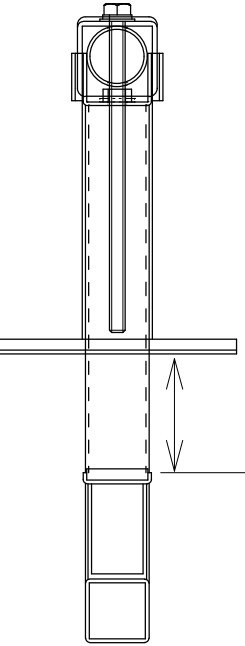

表面処理	種別
溶融亜鉛めっき	N B K S

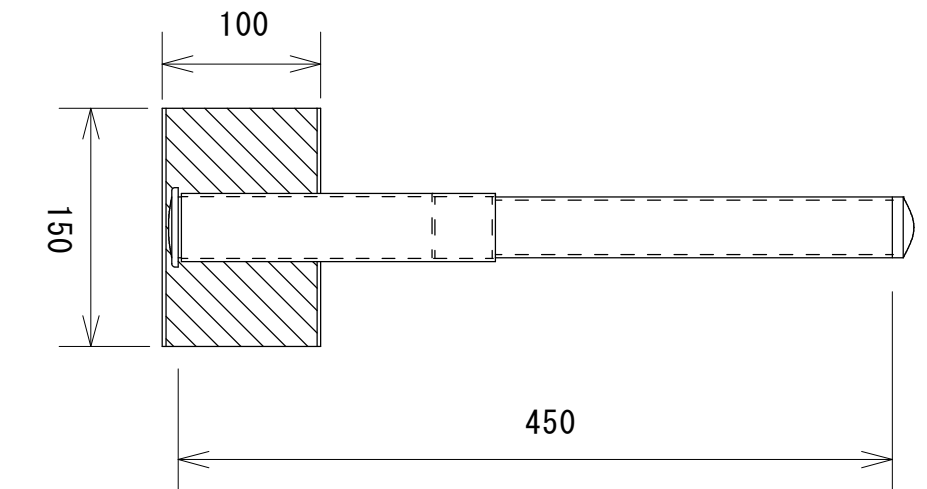
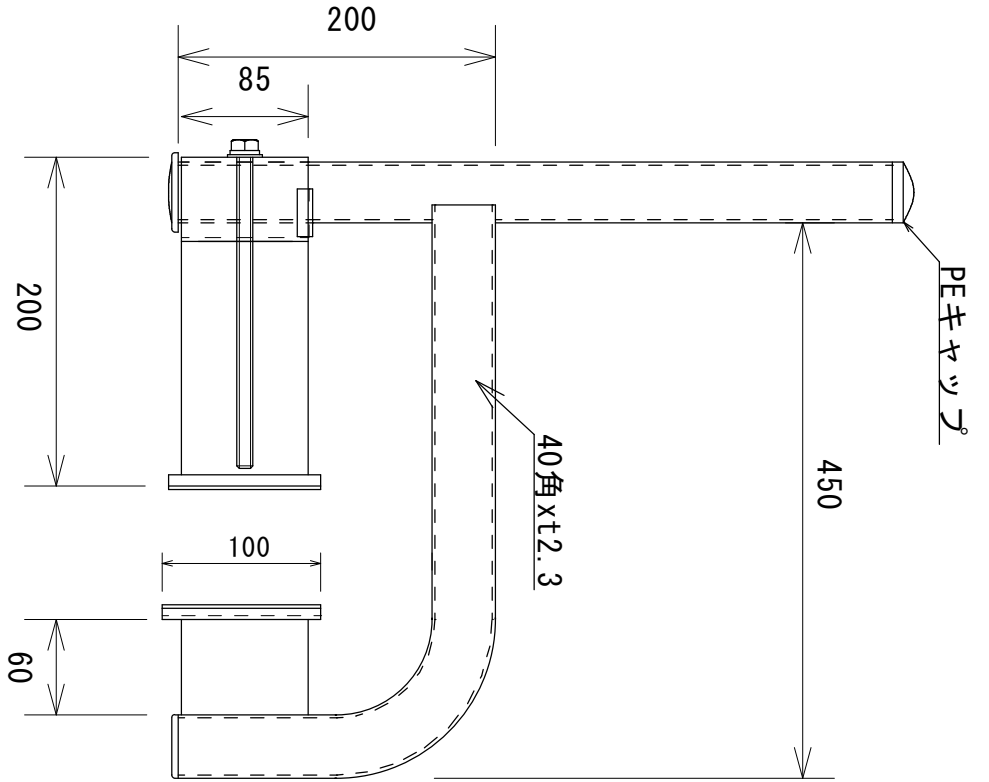
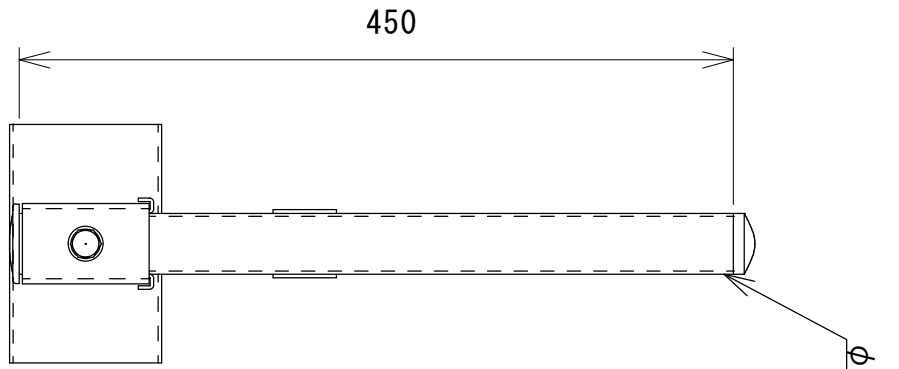

可動範囲
最小180mm~最大300mm

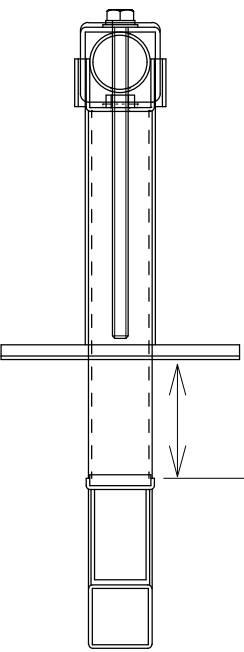

表面処理	種類
溶融亜鉛めっき	NBK L